



JUNO WH



JUNO IX



JUNO BL



JUNO CAST IRON



JUNO ZINC

JUNO

ELICA DESIGN CENTER



Ø 50 cm

Recyclage Recirculatie
Acier inoxydable, blanc, noir
Roestvrij staal, wit, zwarte



ENTRETIEN FACILE



FILTRE LONGUE DURÉE



CM 50



CM 65



Ø150



CLASSE ÉNERGÉTIQUE (A+++D)

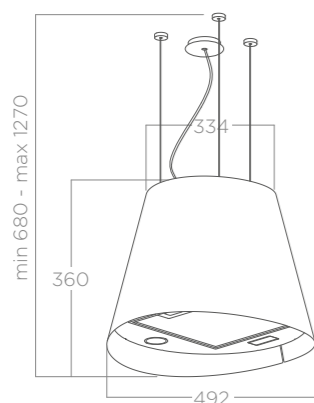

Installation murale possible avec le kit d'installation à commander séparément.
Kan ook aan de wand worden geïnstalleerd door de installatiekit voor accessoires te bestellen.

ECLAIRAGE VERLICHTING	
Type Type	Led 2x2,5 W
Intensité Intensiteit	381 LUX
Température Temperatur	3500 K
PERFORMANCE PRESTATIE	
Commandes Bedieningen	Bouton soft light 3V Bedieningspaneel soft light 3S
Aspiration Max Max. vermogen	620 m³/h
Niveau sonore min-max Geluidsniveau min-max	45 - 67 db(A)
Absorption totale Totale absorptie	205 W

Filtre à graisse en aluminium inclus Aluminium vetfilter meegeleverd
Filtre à charbon régénérable inclus Regeneereerbaar koolstoffilter meegeleverd

ACCESSOIRES TOEBEHOREN	
Filtre à charbon régénérable Regeneereerbaar koolstoffilter	CFC0140088
Kit installation murale inox Set wandmontage staal	KIT0175805
Kit installation murale noir Set wandmontage zwarte	KIT0175806
Kit rallonge câbles (2,5m) Set verlengkabels (2,5 m)	KIT01889
Kit rallonge câbles (5m) Set verlengkabels (5 m)	KIT01921

MODÈLES MODELLEN	
JUNO IX/F/50	PRF0089651D
JUNO BL/F/50	PRF0071970D
JUNO WH/F/50	PRF0071972D

JUNO URBAN

ELICA DESIGN CENTER



Ø 50 cm

Recyclage Recirculatie
Métal effet fonte, métal effet zinc
Gietijzereffect, gegalvaniseerd effect



ENTRETIEN FACILE



FILTRE LONGUE DURÉE



CM 50



CM 65



Ø150



CLASSE ÉNERGÉTIQUE (A+++D)

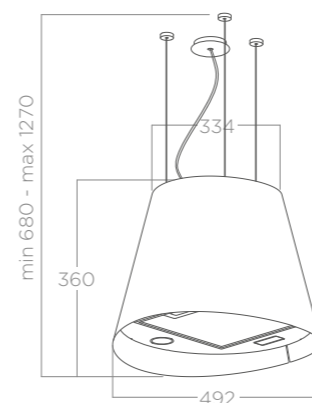

Installation murale possible avec le kit d'installation à commander séparément.
Kan ook aan de wand worden geïnstalleerd door de installatiekit voor accessoires te bestellen.

ECLAIRAGE VERLICHTING	
Type Type	Led 2x2,5 W
Intensité Intensiteit	381 LUX
Température Temperatur	3500 K
PERFORMANCE PRESTATIE	
Commandes Bedieningen	Bouton soft light 3V Bedieningspaneel soft light 3S
Aspiration Max Max. vermogen	620 m³/h
Niveau sonore min-max Geluidsniveau min-max	45 - 67 db(A)
Absorption totale Totale absorptie	205 W

Filtre à graisse en aluminium inclus Aluminium vetfilter meegeleverd
Filtre à charbon régénérable inclus Regeneereerbaar koolstoffilter meegeleverd

ACCESSOIRES TOEBEHOREN	
Filtre à charbon régénérable Regeneereerbaar koolstoffilter	CFC0140088
Kit installation murale inox Set wandmontage staal	KIT0175805
Kit installation murale noir Set wandmontage zwarte	KIT0175806
Kit rallonge câbles (2,5m) Set verlengkabels (2,5 m)	KIT01889
Kit rallonge câbles (5m) Set verlengkabels (5 m)	KIT01921

MODÈLES MODELLEN	
JUNO URBAN CAST IRON/F/50	PRF0147728B
JUNO URBAN ZINC/F/50	PRF0147730B